

CLICK I/O Module Specifications

CO-08TR

8-POINT RELAY OUTPUT MODULE

8-pt 6-240 VAC/6-27 VDC relay output module, 8 Form A (SPST) relays, 2 commons, isolated, 1 A/pt, removable terminal block included (replacement ADC p/n CO-08TB).

Wiring Diagram

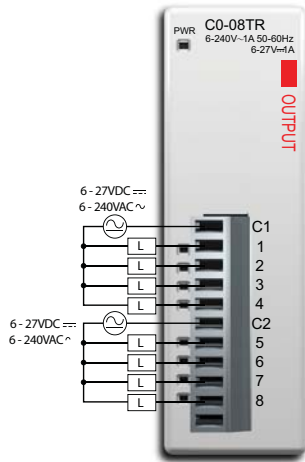

CO-08TR Output Specifications	
Outputs per Module	8
Operating Voltage Range	6-27 VDC / 6-240 VAC
Output Voltage Range	5-30 VDC / 5-264 VAC
Output type	Relay, form A (SPST)
AC Frequency	47-63 Hz
Maximum Current (resistive)	1 A/point
Minimum Load Current	5 mA @ 5 VDC
Maximum Leakage Current	0.1 mA @ 264 VAC
Maximum Inrush Current	3 A for 10 mS
OFF to ON Response	< 15 mS
ON to OFF Response	< 15 mS
Status Indicators	Logic Side (8 points, red LED) Power Indicator (green LED)
Commons	2 (4 points/common) Isolated
Bus Power Required (24 VDC)	Max. 100 mA (All Outputs On)
Protection Circuit	Not built into the module - Install protection elements such as external fuse
Terminal Block Replacement	ADC p/n CO-8TB
Weight	3.9 oz (110 g)

Equivalent Output Circuit

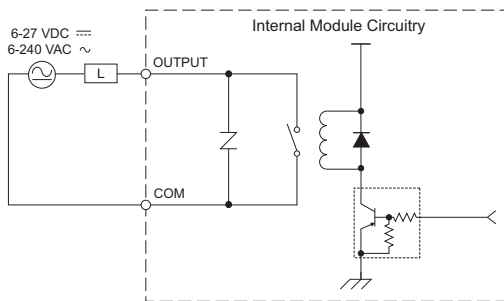

Output Module Temperature Derating Chart*

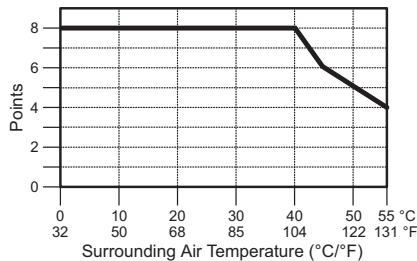

* Only one point on at a time.

Typical Relay Life (Operations) at Room Temperature

Voltage & Load Type	Load Current: 1 A
30 VDC Resistive	300,000 cycles
30 VDC Solenoid	50,000 cycles
250 VAC Resistive	500,000 cycles
250 VAC Solenoid	200,000 cycles

ON to OFF = 1 cycle

ZipLink Pre-Wired PLC Connection Cables and Modules for CLICK PLC

11-pin connector cable
 ZL-C0-CBL11 (0.5 m length)
 ZL-C0-CBL11-1 (1.0 m length)
 ZL-C0-CBL11-2 (2.0 m length)



ZL-RTB20
 20-pin feed-through connector module



Power Budgeting

Power budgeting

There are two areas to be considered when determining the power required to operate a CLICK PLC system. The first area is the power required by the CLICK CPU, along with the internal **logic side** power that the CPU provides to its own I/O and any connected I/O modules that are powered through the CPU's expansion port, plus any device, such as a C-more Micro-Graphic panel, that is powered through one of the CPU's communication ports.

The second area is the power required by all externally connected I/O devices. This should be viewed as the **field side** power required. The field side power is dependent on the voltage used for a particular input or output device as it relates to the wired I/O point, and the calculated load rating of the connected device

It is strongly recommended that the power source for the **logic side** be separate from the power source for the **field side** to help eliminate possible electrical noise.

Power Budgeting requires the calculation of the total current that the 24 VDC power source needs to provide to CLICK's **logic side**, and also a separate calculation of the total current required from all devices operating from the **field side** of the PLC system.

See the Power Budgeting example shown to the right, which includes tables listing the CLICK CPU and I/O module current requirements.

Power Budgeting Using the CLICK Programming Software

The following example shows the **logic side** current consumption as calculated in the CLICK Programming software. Based on the amperage rating of the power supply selected in the first column, your power budget is calculated by subtracting each consecutive module's power consumption from the total available power budget. If you exceed the maximum allowable power consumption the power budget row is highlighted in red.

Power budget row turns red if maximum allowable power consumption is exceeded for your power supply.



CLICK 24 VDC Power Supply
CO-00AC or CO-01AC



Other 24 VDC Power Supply
Example: PSP24-60S

Current Consumption (mA)		
Part Number	Power Budget 24 VDC (logic side)	External 24 VDC (field side)
CPU Modules		
CO-00DD1-D	120	60
CO-00DD2-D	120	0
CO-00DR-D	120	0
CO-00AR-D	120	0
Input Modules		
CO-08ND3	30	0
CO-08ND3-1	30	0
CO-16ND3	40	0
CO-08NA	30	0

Current Consumption (mA)		
Part Number	Power Budget 24 VDC (logic side)	External 24 VDC (field side)
Output Modules		
CO-08TD1	50	15
CO-08TD2	50	0
CO-16TD1	80	100
CO-16TD2	80	0
CO-08TA	80	0
CO-04TRS	100	0
CO-08TR	100	0
C-more Micro-Graphic Panel		
All p/n	90	0

(Example)

Current Consumption (mA) Example		
Part Number	Power Budget 24 VDC (logic side)	External 24 VDC (field side)
CO-00DD1-D	120	60
CO-16ND3	40	0
CO-16TD1	80	100
C-more Micro	90	0
Total:	330	160 *

* Plus calculated load of connected I/O devices.

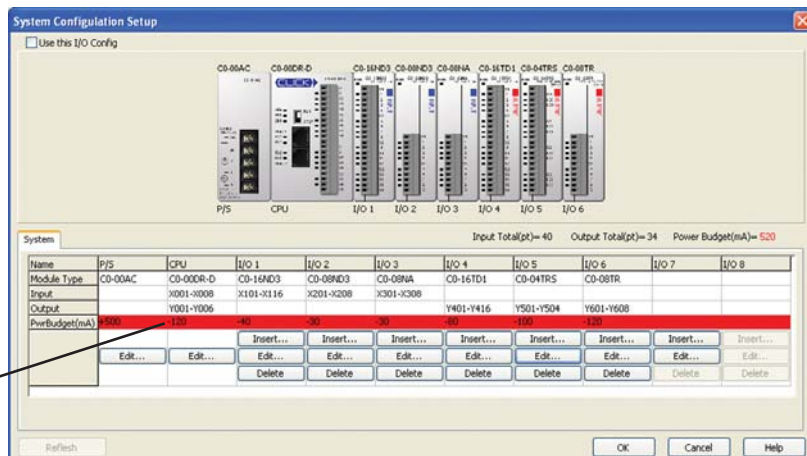
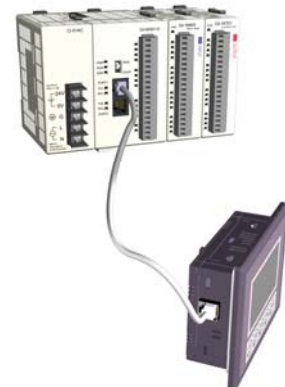



Five-second PLC wiring system

Cut your PLC wiring time down to minutes instead of hours

The ZIPLink wiring system eliminates the normally tedious process of wiring PLC I/O to terminal blocks. Simply plug one end of a ZIPLink pre-wired terminal block cable into your CLICK module and the other end into a ZIPLink connector module. It's that easy. ZIPLinks use half the space, at a fraction of the total cost of terminal blocks.

ZIPLinks are available in a variety of styles to suit your needs, including feedthrough connector module*. ZIPLinks are available for all CLICK CPU modules and all discrete input and output modules.

**Note: only the feedthrough module ZIPLink currently available.*



Specify your ZIPLink system

Use the Compatibility Matrix table below:

Step 1	Locate the CLICK CPU module or I/O module part number.
Step 2	Locate compatible connector module type.
Step 3	Select the cable length by replacing the # symbol with: Blank = 0.5m, -1 = 1.0m, -2 = 2.0m

ZipLink Wiring System Compatibility Matrix for CLICK PLCs				
		Step 2: Connector Module Type		Feedthrough Module
		Step 1: I/O unit	Number of Terminals	Step 3: Cables
CPU Module	CO-00DD1-D	20		ZL-C0-CBL20#
	CO-00DD2-D	20		ZL-C0-CBL20#
	CO-00DR-D	20		ZL-C0-CBL20#
	CO-00AR-D	20		ZL-C0-CBL20#
I/O Module	CO-08ND3	11		ZL-C0-CBL11#
	CO-08NA	11		ZL-C0-CBL11#
	CO-08TD1	11		ZL-C0-CBL11#
	CO-08TD2	11		ZL-C0-CBL11#
	CO-08TR	11		ZL-C0-CBL11#
	CO-08TA	11		ZL-C0-CBL11#
	CO-16ND3	20		ZL-C0-CBL20#
	CO-16TD1	20		ZL-C0-CBL20#
	CO-16TD2	20		ZL-C0-CBL20#
	CO-04TRS*	20		ZL-C0-CBL20#

**Note: The CO-04TRS relay output is derated to 2A per point max. when used with the ZipLink wiring system*