

## ZL-RTB20



### ZL-RTB20 Pinouts

	P1 Connector Pin	TB1 Terminal
TOP ROW	2, 14	1
	15	2
	16	3
	17	4
	18	5
	8, 20	6
	21	7
	22	8
	23	9
	24	10
BOTTOM ROW	1, 13	11
	3	12
	4	13
	5	14
	6	15
	7, 19	16
	9	17
	10	18
	11	19
	12	20

### Typical Internal Circuit

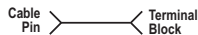

## ZL-RTB40



### ZL-RTB40 Pinouts

		TOP ROW																			
P1 Connector Pin	TB1 Terminal	1	2	3	4	5	6	7	8	9	10	11	12	13	14	15	16	17	18	19	20
		1	2	3	4	5	6	7	8	9	10	11	12	13	14	15	16	17	18	19	20
		BOTTOM ROW																			
P1 Connector Pin	TB1 Terminal	21	22	23	24	25	26	27	28	29	30	31	32	33	34	35	36	37	38	39	40
		21	22	23	24	25	26	27	28	29	30	31	32	33	34	35	36	37	38	39	40

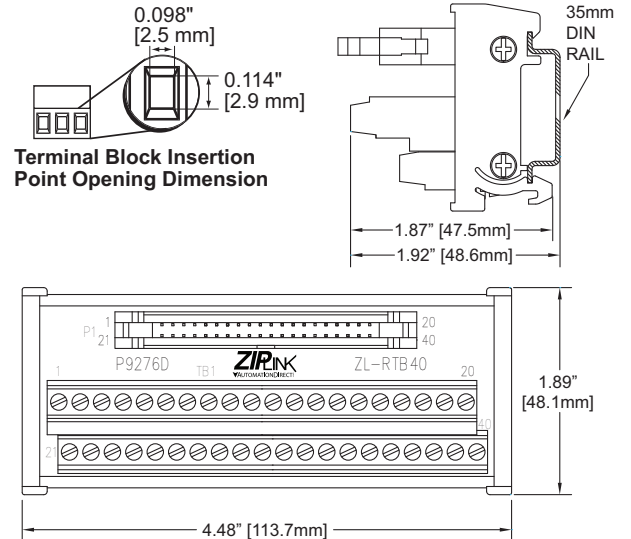
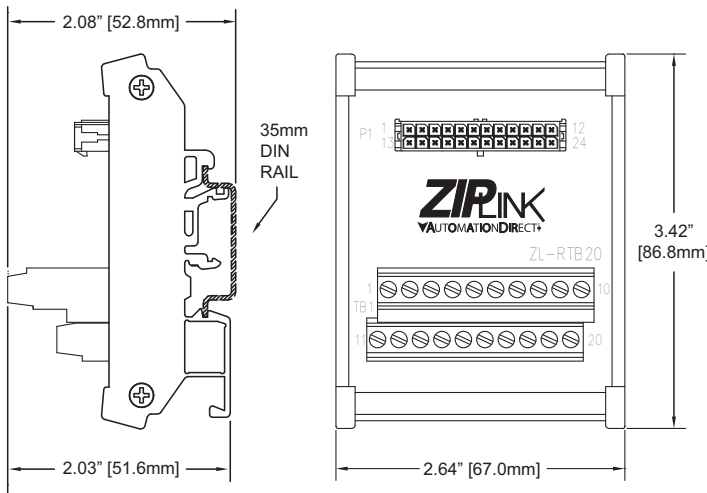

### ZL-RTB20 Specifications

Description*	20-Pole Feedthrough Connector Module
<b>Maximum Voltage</b>	300VAC/VDC
<b>UL Voltage Rating**</b>	0-250VAC/VDC
<b>Maximum Current per Circuit</b>	2A
<b>Maximum Current per Common Circuit†</b>	4A
<b>Maximum Current per Module</b>	40A (all conductors combined including commons)
<b>Number of Terminal Block Positions</b>	20
<b>Surrounding Temperature Range</b>	32 to 140°F (0 to 60°C)
<b>Approvals</b>	File # E200031 UL, cUL, Class 1, Division 2, Groups A,B,C,D Hazardous Locations, CE, EN 61131-2:2007
<b>Terminal Block Contacts</b>	Copper alloy, tin-lead plated
<b>Wire Range (Rated Cross Section)**</b>	12-24AWG Solid or Stranded Copper Conductor (2.5mm <sup>2</sup> )
<b>Wire Strip Length</b>	0.24-0.27" (6-7mm)
<b>Screw Torque</b>	4.4 in-lbs (0.5 Nm)
<b>Connector Type</b>	Molex Micro-Fit 3.0, 24 pin connector Example: Receptacle 43020-2400 Pins 43031 Series, Male
<b>Dimensions (WxHxD)</b>	2.64" x 3.42" x 2.03" (67.0mm x 86.8mm x 51.6mm)
<b>Cable/Wire Clearance</b>	0.5" (12.7mm) Required
<b>Mounting Restrictions</b>	None

†The 4 common circuits are at terminal block positions 1, 6, 11, and 16. Each common circuit has 2 cable wires per terminal.

### ZL-RTB40 Specifications

Description*	40-Pole Feedthrough Connector Module
<b>Maximum Voltage</b>	36VAC/VDC
<b>UL Voltage Rating**</b>	0-30VAC/VDC
<b>Maximum Current per Circuit</b>	500mA
<b>Maximum Current per Module</b>	32A (all conductors combined including commons)
<b>Number of Terminal Block Positions</b>	40
<b>Surrounding Temperature Range</b>	32 to 140°F (0 to 60°C)
<b>Approvals</b>	File # E200031 UL, cUL, Class 1, Division 2, Groups A,B,C,D Hazardous Locations, CE, EN 61131-2:2007
<b>Terminal Block Contacts</b>	Copper alloy, tin-lead plated
<b>Wire Range (Rated Cross Section)**</b>	12-24AWG Solid or Stranded Copper Conductor (2.5mm <sup>2</sup> )
<b>Wire Strip Length</b>	0.24-0.27" (6-7mm)
<b>Screw Torque</b>	4.4 in-lbs (0.5 Nm)
<b>Connector Type</b>	3M 34000 Series IDC Connector, strain relief is required to latch to header. Example: Socket 3417-7640, Strain relief 3448-3040
<b>Dimensions (WxHxD)</b>	4.48" x 1.89" x 1.87" (113.7mm x 48.1mm x 47.5mm)
<b>Cable/Wire Clearance</b>	0.5" (12.7mm) Required
<b>Mounting Restrictions</b>	None

\*Connecting cables are for internal wiring only.

\*\*Use Class 2 power supply. Use conductors rated 60°/75°C.

## Apply ZIPLink Labels

(Supplied with ZIPLink cables)

**1** Find correct label and remove from sheet

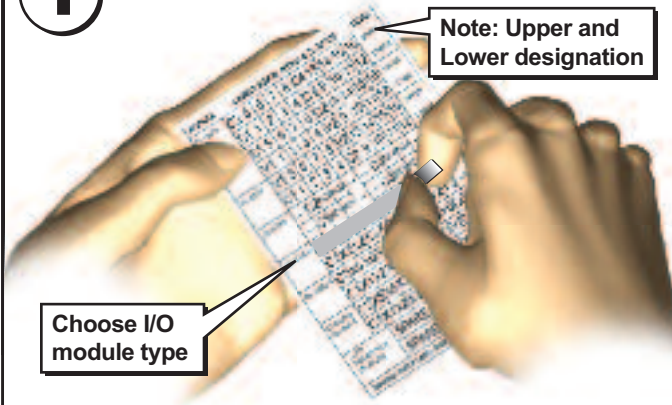

**2** Apply label to designated position

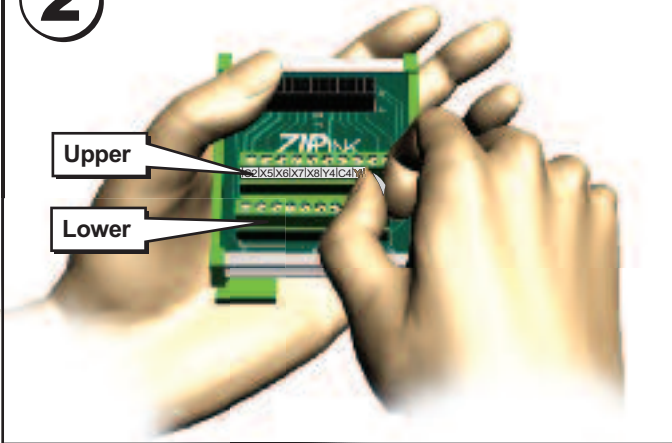

## DIN Rail Installation and Removal

To install ZIPLink module, insert upper tab into DIN rail.

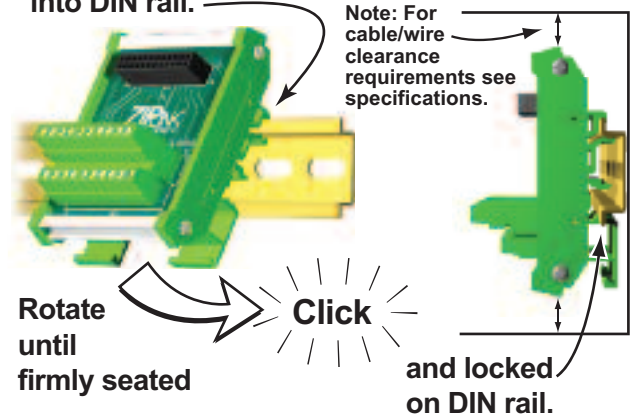

To remove ZIPLink module, insert screwdriver between Tab 1 and module.

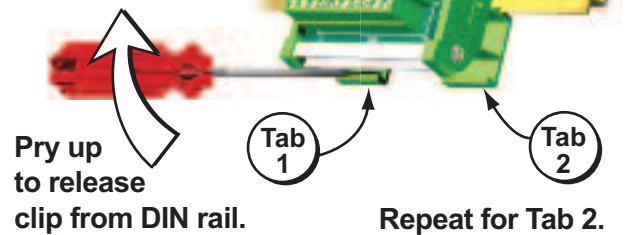

**WARNING:** To minimize the risk of potential safety problems, you should follow all applicable local and national codes that regulate the installation and operation of your equipment. These codes vary from area to area and it is your responsibility to determine which codes should be followed, and to verify that the equipment, installation, and operation are in compliance with the latest revision of these codes.

Equipment damage or serious injury to personnel can result from the failure to follow all applicable codes and standards. We do not guarantee the products described in this publication are suitable for your particular application, nor do we assume any responsibility for your product design, installation, or operation.

If you have any questions concerning the installation or operation of this equipment, or if you need additional information, please call Technical Support at 01737 824600.

This publication is based on information that was available at the time it was printed. At AutomationDirect.com® we constantly strive to improve our products and services, so we reserve the right to make changes to the products and/or publications at any time without notice and without any obligation. This publication may also discuss features that may not be available in certain revisions of the product.

## ZL-RTB20 ZIPLink Cable Removal

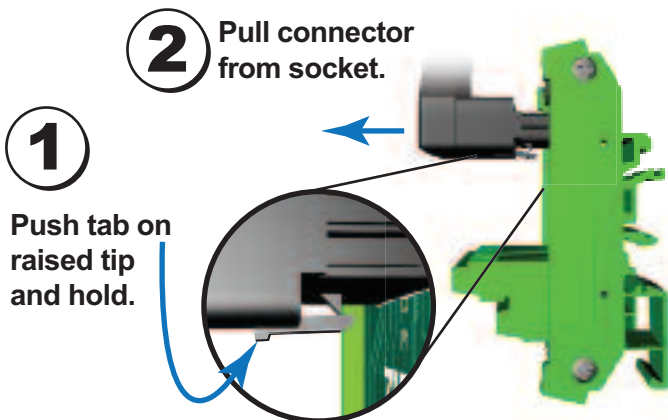

**HAZARD WARNING**

- A. THIS EQUIPMENT IS SUITABLE FOR USE IN CLASS I, DIVISION 2/ZONE 2, GROUPS A, B, C AND D OR NON-HAZARDOUS LOCATIONS ONLY.
- B. **WARNING – EXPLOSION HAZARD** – SUBSTITUTION OF COMPONENTS MAY IMPAIR SUITABILITY FOR CLASS I, DIVISION 2/ZONE 2.
- C. **WARNING – EXPLOSION HAZARD** – DO NOT CONNECT OR DISCONNECT CONNECTORS OR OPERATE SWITCHES WHILE CIRCUIT IS LIVE UNLESS THE AREA IS KNOWN TO BE NON-HAZARDOUS.
- D. ALL MODULES USED WITH ACCESSORIES MUST USE R/C (ECBT2) MATING PLUG FOR ALL APPLICABLE MODELS. ALL MATING PLUGS SHALL HAVE SUITABLE RATINGS FOR DEVICE.